

EFM[®]32

... the world's most energy friendly microcontrollers

Oscillator Design Considerations

AN0016 - Application Note

Introduction

The EFM32 microcontrollers contain two crystal oscillators, one low speed (32.768 kHz) and one high speed (4-32 MHz or 4-48 MHz). This application note is to provide an introduction to these oscillators and provide guidelines in selecting correct components for the oscillator circuits in the EFM32 devices. Topics covered include oscillator theory and some recommended crystals for the EFM32 devices.

This application note includes:

- This PDF document

1 Oscillator Theory

1.1 What is an oscillator

An oscillator is an electronic circuit which generates a repetitive time-varying signal, which in this context is used to clock communication and the execution of instructions in the EFM32 microcontroller. Several ways of generating such a signal exists, all with different properties that influences cost, size and stability of the clock signal.

- *RC oscillators* are built from resistors, capacitors and an inverting amplifier. They come at a low cost and have a shorter startup time than the crystal oscillator, but variations in component values over temperature makes it difficult to precisely determine the oscillation frequency. The EFM32-series of microcontrollers provide two internal RC-oscillators, one high frequency RC oscillator (HFRCO) and one low frequency RC oscillator (LFRCO). In addition, an auxiliary 14MHz RC oscillator (AUXHFRCO) is used for flash programming and debug trace. While the internal RC-oscillators will ensure proper operation of the EFM32, some applications require higher accuracy than these can provide.
- *Crystal oscillators* uses the mechanical vibration of a crystal to generate the clock signal. Due to the molecular composition of the crystal matter and the angle of which the crystal is cut, this type of oscillator is very precise and stable over a wide temperature range. The most commonly used crystal is the quartz crystal. Producing quartz crystals require very stable temperature and pressure conditions over a few weeks. This makes crystal oscillators more expensive than RC oscillators.
- *Ceramic resonators* operate in the same way as crystal oscillators. They are easier to manufacture and therefore cheaper than quartz crystals, but suffer from inferior precision in the oscillation frequency. As will be seen in subsequent chapters, the quality factor for ceramic resonators are lower than for crystal oscillators, which usually results in a faster startup time. This can be more important than precision in frequency for some applications.

This application note will focus on quartz crystals, however the theory presented is also valid for ceramic resonators.

1.1.1 Piezoelectricity

Quartz crystals and ceramic resonators hold the direct piezoelectric property. This means an applied electric field will cause the crystal to deform. Conversely, a deformation of the crystal will cause a voltage across the terminals. Once the oscillator has started, the changing voltage on the terminals of the vibrating crystal is used as the clock signal.

1.2 Basic Principle of Oscillators

Figure 1.1. Feedback Oscillator Loop

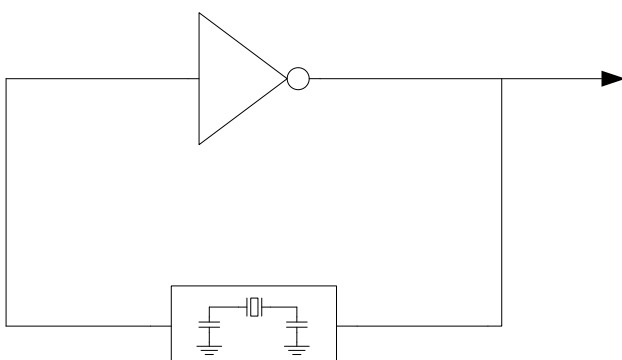

The principle behind the oscillator is a positive feedback loop satisfying the Barkhausen condition: If the closed-loop gain is larger than unity and the total phase lag is 360° , the resulting closed-loop system is unstable and will self-reinforce. This is a necessary, but not sufficient, condition for oscillations to be present. When the necessary conditions are met, any disturbance (noise) in the oscillator will cause oscillations to start. The frequency that fulfills the Barkhausen condition is amplified the most, because it is in phase with the original signal.

The initial oscillations are very weak and it takes time to amplify the signal to the desired magnitude. When oscillations are established, only a small amount of energy is needed to compensate for losses in the circuit. Mathematically, a closed-loop gain of one is required to maintain steady state oscillations. The EFM32 relies on an internal regulator to adjust the closed-loop gain to unity when the clock signal reaches the desired amplitude.

From Figure 1.1 (p. 2) it is seen that the oscillator circuitry consists of two parts; an amplification stage and a filter that decides which frequency experience a 360° phase lag. In the case of a crystal oscillator, the filter consists of the crystal and external load capacitors.

1.2.1 Startup time

The magnitude of the closed-loop gain has great influence on the startup time. With high gain, the number of times the signal has to be propagated around the loop to reach the desired amplitude is reduced. For fast startup, a high gain is preferred.

For the same reason, the oscillation frequency influences the startup time. A crystal in the kHz range would have a considerably longer startup time than a crystal in the MHz range because the time it takes to circulate the loop is longer. Typical startup times for the EFM32 is 200-400 ms for low frequencies and 200 μ s to 400 μ s in the high frequency domain.

1.3 Modeling the Crystal

The crystal can be described by the electrical equivalent circuit in Figure 1.2 (p. 3) .

Figure 1.2. The Electric Equivalent Circuit of a Crystal

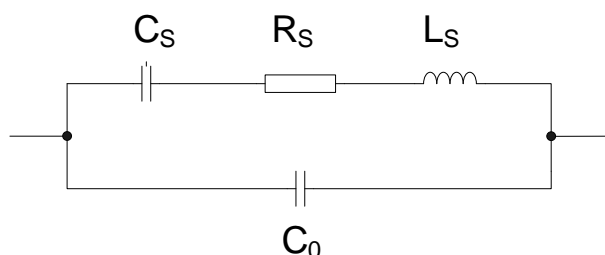

- C_S is the motional capacitance. It represents the piezoelectric charge gained from a displacement in the crystal.
- R_S is the motional resistance. It represents the mechanical losses in the crystal.
- L_S is the motional inductance. It represents the moving mass in the crystal.
- C_0 is the shunt capacitance between the electrodes and stray capacitance from the casing.

For low frequencies, the electrical equivalent circuit will exhibit capacitive behavior as depicted in Figure 1.3 (p. 4). The presence of the inductor becomes more noticeable as the frequency, and thus reactance, increases. Ignoring the shunt capacitance C_0 , the series resonant frequency is defined where the reactance of the inductor and capacitor cancels. At this frequency the crystal appears only resistive with no shift in phase. The series resonance frequency therefore decides the values of C_S and L_S and

can be calculated with Equation 1.1 (p. 4). The series resonance frequency is the natural resonance frequency where the energy transformation between mechanical and electrical energy is most effective.

Figure 1.3. Reactance vs. Frequency

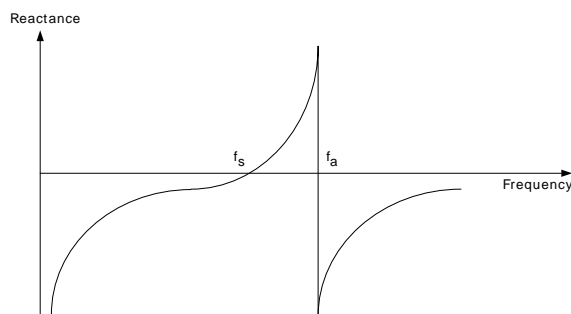

Crystal Oscillator Series Resonant Frequency

$$f_S = 1 / (2 \pi (L_S C_S)^{1/2}) \quad (1.1)$$

At higher frequencies, the equivalent circuit will appear inductive, which implies higher impedance. When the inductive reactance from the crystal cancels the capacitive reactance from shunt capacitance C_0 , another resonance frequency with zero phase shift exists. This frequency is called the anti-resonant frequency, f_A . At this frequency, the impedance is at its maximum. The inductance in the crystal and the shunt capacitance will feed each other and the lowest possible current draw is obtained.

Crystal Oscillator Anti-Resonant Frequency

$$f_A = 1 / (2 \pi (L_S \times C_S C_0 / (C_S + C_0))^{1/2}) \quad (1.2)$$

The range of frequencies between f_S and f_A is called the area of parallel resonance and is where the crystal normally will oscillate. At the resonant frequency, the phase lag in the feedback loop is provided by an amplifier with 180° phase lag and two capacitors with a combined 180° phase lag. In practice, the amplifier provides a little more than 180° phase shift, which means the crystal has to appear slightly inductive to fulfill the Barkhausen criterion.

1.3.1 Series and Parallel Resonant Crystals

Physically there are no difference between series and parallel resonant crystals. Series resonant crystals are specified to oscillate at the series resonance frequency where the crystal appears with no reactance. Because of this, no external capacitance should be present as this would lower the oscillating frequency to below the natural resonance frequency. These crystals are intended for use in circuits with no external capacitors where the oscillator circuit provides 360° phase shift.

Parallel resonant crystals requires an external capacitive load to oscillate at the specified frequency and this is the resonance mode required for the EFM32. The exact oscillation frequency for a parallel resonant crystal can be calculated with Equation 1.3 (p. 4), where C_L is the external capacitance seen by the crystal. C_L is therefore an important design parameter and is given in the datasheet for parallel resonant crystals.

Parallel Crystal Oscillator Frequency

$$f_P = f_S(1 + C_S / 2C_L) \quad (1.3)$$

2 EFM32 Crystal Oscillators

The EFM32 devices include a variety of oscillators, including fully internal low speed and high speed RC oscillators (not covered by this application note). These enable full operation in all energy modes without any external oscillator components. If the application requires a more accurate clock, the EFM32 includes two crystal oscillators, the Low Frequency Crystal Oscillator (LFXO) and the High Frequency Crystal Oscillator (HFXO). These oscillators require an external clock or crystal and load capacitors connected to the crystal oscillator pins of the EFM32. The LFXO supports crystals with a nominal frequency of 32.768 kHz, while the HFXO supports frequencies from 4 to 32 MHz (Up to 48 MHz in parts that support this frequency for the system clock). External oscillators which provide sine and square waves are also supported, see AN0002 Hardware Design Considerations for register settings and pin connections. Both the high and low frequency clock sources can be used simultaneously.

In the EFM32 the oscillator circuits are designed as a Pierce oscillator as shown in Figure 2.1 (p. 5) .

Figure 2.1. The Pierce Oscillator in the EFM32

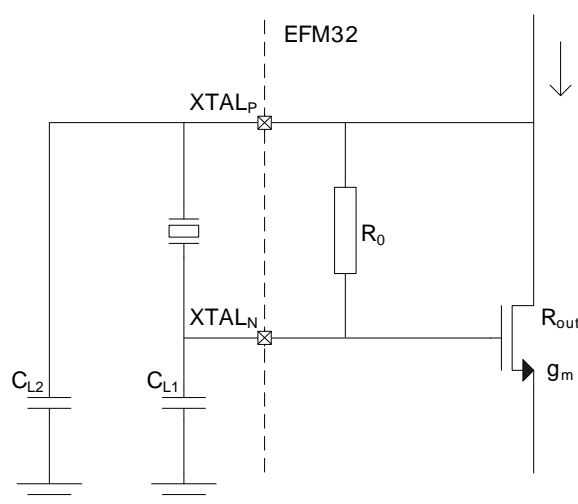

The Pierce oscillator is known to be stable for a wide range of frequencies and for its low power consumption.

The EFM32 crystal oscillators use a relatively low oscillation amplitude, which can lead to a lower oscillation frequency than stated as the nominal value in the crystals datasheet. More information on this effect is given in Section 3.4 (p. 8) .

2.1 Timeout and Glitch Detection

To ensure that the XO clock signals are not used internally in the EFM32 before they are stable, both the HFXO and the LFXO include a configurable timeout (configured in LFXOTIMOUT and HFXOTIMEOUT in CMU_CTRL). When the XO starts up the timeout counter will count to the configured number of cycles before the clock signal propagates to the internal clock trees and the digital logic. For the HFXO there is also a glitch detector that can be enabled (HFXOGLITCHDETEN in CMU_CTRL). With this set, any glitches detected during the timeout period will result in the timeout counter starting over again. The clock will then not propagate until it has run a full timeout period without glitches. After the timeout period has passed successfully the glitch detector is turned off automatically to save power.

2.2 Oscillator Configuration in energyAware Designer

The energyAware Designer in Simplicity Studio contains a tool to help users configure both load capacitance and software settings for using the LFXO and the HFXO. Once the correct HW configuration has been found the Designer can output C-code which should be run in the application. It is important that the SW settings from the Designer are used, to ensure reliable operation of the oscillator.

2.3 External Clock and Buffered Sine Input

The HFXO and LFXO oscillators can be used as inputs for an externally generated digital clock signal. When using the oscillators in this way, connect the clock input to HFXTAL_N or LFXTAL_N and configuring . The max frequency of these inputs are limited by the max clock frequency of the device (32 or 48 MHz). An externally buffered sine signal can also be applied to the HFXTAL_N or LFXTAL_N pin. The amplitude of this signal must be at least 200 mV peak-to-peak, and the frequency must be the same as required when using crystals with the HFXO and LFXO. The oscillation mode for the LFXO and HFXO is configured in HFXOMODE/LFXOMODE in CMU_CTRL.

3 Crystal Parameters

3.1 Quality Factor

The quality factor Q is a measure of the efficiency or the relative storage of energy to dissipation of energy in the crystal. For the electrical-equivalent circuit, Equation 3.1 (p. 7) states the relation between R, C and Q. In practice, crystals with higher Q-values are more accurate, but have a smaller bandwidth for which they oscillate. Therefore, high Q-factor crystals will normally start slower than crystals with higher frequency tolerance. Typically, crystals have higher Q-factor than ceramic resonators. Crystals would therefore be expected to have a longer startup time than ceramic resonators.

Q-Factor

$$Q = X_{L_S} / R_S = 1 / (X_{C_S} R_S) = 1 / (2 \pi f C_S R_S) = 2 \pi f L_S / R_S \quad (3.1)$$

X_{L_S} and X_{C_S} are the reactance of L_S and C_S , respectively, at the operating frequency of the crystal.

3.2 Load Capacitance

As seen in Figure 2.1 (p. 5), the two capacitors C_{L1} and C_{L2} are the loads of the crystal. The effective load capacitance, C_L , as seen from the XTAL_N and XTAL_P pins on the EFM32 is the series combination of C_{L1} and C_{L2} through ground.

Load Capacitance

$$C_L = (C_{L1} \times C_{L2}) / (C_{L1} + C_{L2}) + C_{\text{stray}} \quad (3.2)$$

Where C_{stray} is the pin capacitance of the microcontroller and any parasitic capacitance, and can often be assumed in the range 2-5pF. Right choice of C_L is important for proper operating frequency. Crystals with small load capacitance would typically start faster than crystals requiring a large C_L . Large load capacitors also increase power consumption. It is recommended to use a crystal with C_L as specified in Chapter 5 (p. 11). The EFM32 device datasheets also contain more information on the allowed load capacitance range.

3.3 Equivalent Series Resistance

The Equivalent Series Resistance is the resistance in the crystal during oscillation and varies with the resonance frequency. ESR, as given in Equation 3.3 (p. 7), will typically decrease with increasing oscillation frequency.

Equivalent Series Resistance

$$\text{ESR} = R_S(1 + C_0/C_L)^2 \quad (3.3)$$

The HFXO/LFXO circuits of the EFM32 cannot guarantee startup of crystals with ESR larger than a certain limit. Please refer to the device datasheet for further details. The smaller the ESR, compared to this maximum value, the better gain margin for startup of the crystal which in turn reduces the startup time. Additionally, a small ESR value gives lower power consumption during oscillation.

Note that HF crystals have ESR of a few tens of Ohms as compared to the LF crystals which have ESR values normally measured in kOhm. Therefore a few Ohm of series resistance has more influence on the startup margin in the MHz range as compared to the kHz range.

3.4 Frequency Pulling

As the crystal oscillators in the EFM32 use a relatively low oscillation amplitude, the oscillation frequency can be lower than stated in the datasheet when using the suggested load capacitance. This offset is best found by measuring the resulting frequency when using the suggested load capacitance. The offset will be stable and not affected by temperature, voltage or aging. If it is desirable to achieve the nominal frequency given for the crystal, there are two options:

Option A:

Order a crystal from the crystal vendor that has a nominal frequency equal to the frequency you want to achieve plus the measured offset frequency.

Option B:

It is possible to slightly alter the oscillation frequency of a crystal by adjusting the load capacitance (C_{L1} and C_{L2}). The pullability of the oscillation system refers to which extent it is possible to tune the resonance frequency of the crystal by changing these values. The crystal sees these capacitors in series through ground, parallel to the closed loop. They will therefore slightly alter the anti-resonance frequency of the crystal. Equation 3.4 (p. 8) shows the pullability in terms of frequency change in ppm per change in combined load capacitance in pF.

Pullability

$$\text{Average pullability (ppm/pF)} = C_s \times 10^6 / 2 (C_0 + C_L)^2 \quad (3.4)$$

3.5 Drive Level

Drive level is a measure of the power dissipated in the crystal. The crystal manufacturer states the maximum value tolerated by the crystal. Exceeding this value can damage the crystal.

Drive Level

$$DL = ESR \times I^2 \quad (3.5)$$

I is the RMS current flowing through the crystal. An external resistor can be added to limit the drive level if necessary; however this is not recommended unless DL is too high since it reduces the gain margin and increases power consumption of the oscillator.

3.6 Minimum Negative Resistance

A critical condition for oscillations to build up requires the energy supplied to exceed the energy dissipated in the circuit. In other words, the negative resistance of the amplifier has to exceed the equivalent series resistance in the crystal. An approximate formula for negative resistance is given in Equation 3.6 (p. 8) .

Negative resistance

$$R_{\text{neg}} = -g_m / ((2 \pi f)^2 \times C_{L1} C_{L2}) \quad (3.6)$$

Where g_m is the transconductance of the oscillator circuitry. To ensure safe operation over all voltage and temperature variations, the lowest allowed R_{neg} is given by Equation 3.7 (p. 8) .

Minimum negative resistance

$$-R_{\text{neg}} > 2 \times ESR_{\text{max}} \quad (3.7)$$

If the negative resistance is not high enough to satisfy this criterion, another crystal with lower ESR and/or load capacity requirements should be chosen. The XO Configurator in the energyAware Designer is able to calculate the R_{neg} value for your design based on the load and shunt capacitance, internal loss and frequency. Equation 3.6 (p. 8) shows an approximate formula for this calculation which excludes shunt capacitance and internal loss.

3.7 Frequency Stability

Frequency stability is the maximum frequency deviation from the specified oscillating frequency over the given operating temperature range.

3.8 Frequency Tolerance

Frequency tolerance is the maximum frequency deviation from the specified oscillating frequency at 25°C. This parameter gives an indication of variations between individual crystals.

3.9 PCB Layout

To minimize noise sensitivity caused by parasitic antenna and spurious coupling phenomena, the distance between the crystal, capacitors and the EFM32s oscillator pins should be as short as possible. If it is not possible to place the external oscillator components close to the oscillator pins, care should be taken when routing these signals. Avoid long traces underneath the EFM32 package and other circuitry that could create spurious coupling with logic activity. Also avoid routing any other signals through the crystal area.

The ground side of the two capacitors must be connected to ground. These connections should be as short as possible and of equal length for each of the capacitors. Ensure that the ground plane underneath the oscillator is of good quality. Do not use a separate ground plane under the oscillator with a narrow connection to the reference ground as this can act as an antenna. To avoid coupling from surrounding signal traces, it is a good practice to place a grounded guard ring around the oscillator and its components.

3.10 Software Configuration

The EFM32 allows for run-time configuration of the transconductance (g_m) of the HFXO and the LFXO during oscillation build-up. The following bit fields are used:

HFXO:

- HFXOBOOST[1:0] in CMU_CTRL

LFXO:

- LFXOBOOST in CMU_CTRL
- REDLFXOBOOST in EMU_AUXCTRL (not available in all devices)

The recommended settings for these bits depend on the load and shunt capacitances of the oscillator design. The LFXO/HFXO configurator in the energyAware Designer in Simplicity Studio creates C-code that sets these configuration bits correctly according to the frequency, maximum ESR, shunt and load capacitance of the crystal. It is important that these recommendations are followed as incorrect settings can lead to unreliable operation of the crystal oscillator.

4 Reducing Power Consumption

The power consumption of the crystal oscillator is mostly determined by the drive level of the oscillator. This equals the power dissipated in the crystal as given in Equation 4.1 (p. 10) .

Drive Level/Power Dissipation in Crystal

$$DL = 1/2 \times ESR \times (2 \pi f \times V_{pp} \times (C_0 + C_L))^2 \quad (4.1)$$

V_{pp} is the peak to peak voltage across the crystal at the resonance frequency.

Because the internal buffer draws some current regardless of clock frequency, the average power consumption per MHz is usually lower for high clock frequencies. In the energy conscious sense it is therefore favorable to alternate between short periods in run mode with HFXO enabled and lower energy modes where HFXO is not running. Since the startup time depends on clock frequency, high frequency crystals are recommended to reduce the startup time.

During startup the current consumption is higher than after oscillations has stabilized. A short startup time reduces the period of which the current consumption of the oscillator is high and is therefore essential if the oscillator is frequently switched on and off. In general one would like the circuit to be operational as fast as possible and a fast startup time is therefore favorable. Crystals with low ESR and load capacitance typically have the shortest startup time and consumes the least amount of power.

Energy consumption can be reduced by choosing a HFXO crystal in the lower frequency range in applications where entering a deeper sleep mode is not feasible.

5 Recommended Crystals

When deciding upon which crystal to employ, the following considerations could be helpful to ensure a proper functioning oscillator.

- *Precision.* High quality crystals are very precise, but come at a higher cost. Ceramic resonators are cheaper, but less precise. However, if no special precision is needed, the internal RC oscillators consume less power at the same frequency. Consult the device datasheet for details.
- *Operating environment.* Temperature, humidity and mechanical vibration affects the stability properties. For crystals, define what crystal cut is more appropriate. For most applications, AT cut is an excellent choice due to good temperature stability over a wide temperature range. SC cut has good stability when exposed to mechanical vibrations, but suffers from humidity and temperature changes. Many more cuts with different properties exists.
- *Package.* Surface mount or through-hole. If size is critical, define maximum package dimensions.
- *Find load capacitors.* If $C_{L1, L2}$ is within range specified by the crystal datasheet, check if it meets a standard capacitor value. If not, use the nearest value available. A variable capacitor can be used to pull the correct frequency if desired.
- *Calculate negative resistance.* If the magnitude of the negative resistance is less than $2 \times ESR_{max}$, then find another crystal or adjust the load capacitance.

The recommended crystals are chosen from a selection of popular crystals with different ESR, cost, frequency stability and tolerance. By examining the list of considerations above, one should be able to find a suitable crystal.

All the recommended crystals are fundamental mode, as is recommended for the EFM32.

5.1 Crystal Specifications

Table 5.1. 48MHz Crystals

Mfg	Part	ESR	C ₀	C _L	DL	Tolerance	Footprint
Abracon	ABM2-48.000MHZ-D4YF-T	50 Ohm	7 pF	18 pF	10 μW	30 PPM	8.0x4.5 mm
Abracon	ABM7-48.000MHZ-D-2-Y-F-T	70 Ohm	7 pF	18 pF	10 μW	20 PPM	6.0x3.5 mm
Abracon	ABM8G-48.000MHZ-18-D2Y-T	50 Ohm	7 pF	18 pF	10 μW	20 PPM	3.2x2.5 mm
Abracon	ABM10-48.000MHZ-D30-T3	70 Ohm	7 pF	10 pF	10 μW	30 PPM	2.5x2.0 mm
Abracon	ABM11-48.000MHZ-D2X-T3	60 Ohm	7 pF	10 pF	10 μW	20 PPM	2.0x1.6 mm
ECS Inc	ECS-480-18-23A-EN-TR	40 Ohm	7 pF	18 pF		30 PPM	6.0x3.5 mm
NDK	NX5032GA-48.000MHZ	50 Ohm		8 pF	50 μW	20 PPM	5.0x3.2 mm

Table 5.2. 32MHz Crystals

Mfg	Part	ESR	C ₀	C _L	DL	Tolerance	Footprint
ECS Inc	ECS-320-20-30B-DU	30 Ohm	5 pF	20 pF	61 μW	30 PPM	5.0x3.2 mm
TXC	7B-32.000MAAJ-T	40 Ohm	5 pF	18 pF	68 μW	30 PPM	5.0x3.2 mm
Abracon	ABM8G-32.000MHZ-B4Y-T	50 Ohm	5 pF	10 pF	36 μW	30 PPM	3.2x2.5 mm
Citizen	CS325H-32.000MEDQ-UT	50 Ohm	5 pF	10 pF	36 μW	10 PPM	3.2x2.5 mm
NDK	NX2520SA-32.000000MHZ	50 Ohm		10 pF	36 μW	10 PPM	2.5x2.0 mm
NDK	NX3225SA-32.000000MHZ	50 Ohm		8 pF	27 μW	15 PPM	3.2x2.5 mm
NDK	NX5032GA-32.000000MHZ	50 Ohm		8 pF	27 μW	50 PPM	5.0x3.2 mm
NDK	NX8045GB-32.000000MHZ	50 Ohm		8 pF	27 μW	50 PPM	8.0x4.5 mm

Table 5.3. 4MHz Crystals

Mfg	Part	ESR	C ₀	C _L	DL	Tolerance	Footprint
CTS	ATS040SM-T	120 Ohm	7 pF	20 pF	4 μW	30 PPM	HC49
Abracon	ABLS2-4.000MHZ-D4Y-T	180 Ohm	7 pF	18 pF	6 μW	30 PPM	HC49
Abracon	ABLS-4.000MHZ-B2-T	180 Ohm	7 pF	18 pF	6 μW	20 PPM	HC49
Fox Electronics	FQ1045A-4.000	150 Ohm	7 pF	20 pF	6 μW	30 PPM	10.0x4.5 mm
Fox Electronics	FOXSDLF/040	200 Ohm	7 pF	20 pF	7 μW	50 PPM	13.9x5.0 mm
TXC	9C-4.000MAAJ-T	150 Ohm	7 pF	18 pF	5 μW	30 PPM	HC49

Table 5.4. 32768Hz Crystals

Mfg	Part	ESR	C ₀	C _L	DL	Tolerance	Footprint
Epson Toyocom	MC-405 32.7680K-A0	35 kOhm	0.85 pF	12.5 pF	21 nW	20 PPM	10.4x4.0 mm
Epson Toyocom	MC-306 32.7680K-A0	50 kOhm	0.9 pF	12.5 pF	23 nW	20 PPM	8.0x3.8 mm

Mfg	Part	ESR	C ₀	C _L	DL	Tolerance	Footprint
Abracon	ABS10-32.768KHZ-1-T	70 kOhm	1 pF	12.5 pF	43 nW	10 PPM	4.9x1.8 mm
Citizen	CM315-32.768KEZF-UT	70 kOhm	1.05 pF	12.5 pF	44 nW	10 PPM	3.2x1.5 mm
Citizen	CFS206-32.768KDZF-UB	35 kOhm	1.35 pF	12.5 pF	23 nW	20 PPM	Cylinder
Fox Electronics	FX135A-327	70 kOhm	1 pF	12.5 pF	43 nW	20 PPM	3.2x1.5 mm
Golledge	GSWX26	35 kOhm	1.35 pF	12.5 pF	23 nW	20 PPM	Cylinder

DL = Drive Level

6 Revision History

6.1 Revision 1.21

2012-04-18

Corrected typos in XO Configurator description.

6.2 Revision 1.20

2012-04-03

Updated recommendations on minimum negative resistance and removed recommendations on gain margin.

Added information on timeout counter and glitch detection.

Added PCB layout recommendations.

Added information on external clock and buffered sine input.

Added information on XO Configuration in energyAware Designer. Removed recommendations on how to use LFXOBOOST in CMU_CTRL as this is now covered by the eA Designer.

Removed crystal selection spreadsheet.

Added recommended 48 MHz crystals.

6.3 Revision 1.10

2011-08-10

Updated recommendations on use of LFXOBOOST.

Updated recommended crystals in document and spreadsheet for LFXO.

6.4 Revision 1.00

2010-07-20

Initial revision.

A Disclaimer and Trademarks

A.1 Disclaimer

Energy Micro AS intends to provide customers with the latest, accurate, and in-depth documentation of all peripherals and modules available for system and software implementers using or intending to use the Energy Micro products. Characterization data, available modules and peripherals, memory sizes and memory addresses refer to each specific device, and "Typical" parameters provided can and do vary in different applications. Application examples described herein are for illustrative purposes only. Energy Micro reserves the right to make changes without further notice and limitation to product information, specifications, and descriptions herein, and does not give warranties as to the accuracy or completeness of the included information. Energy Micro shall have no liability for the consequences of use of the information supplied herein. This document does not imply or express copyright licenses granted hereunder to design or fabricate any integrated circuits. The products must not be used within any Life Support System without the specific written consent of Energy Micro. A "Life Support System" is any product or system intended to support or sustain life and/or health, which, if it fails, can be reasonably expected to result in significant personal injury or death. Energy Micro products are generally not intended for military applications. Energy Micro products shall under no circumstances be used in weapons of mass destruction including (but not limited to) nuclear, biological or chemical weapons, or missiles capable of delivering such weapons.

A.2 Trademark Information

Energy Micro, EFM32, EFR, logo and combinations thereof, and others are the registered trademarks or trademarks of Energy Micro AS. ARM, CORTEX, THUMB are the registered trademarks of ARM Limited. Other terms and product names may be trademarks of others.

B Contact Information

B.1 Energy Micro Corporate Headquarters

Postal Address	Visitor Address	Technical Support
Energy Micro AS P.O. Box 4633 Nydalen N-0405 Oslo NORWAY	Energy Micro AS Sandakerveien 118 N-0484 Oslo NORWAY	support.energymicro.com Phone: +47 40 10 03 01

www.energymicro.com

Phone: +47 23 00 98 00

Fax: + 47 23 00 98 01

B.2 Global Contacts

Visit **www.energymicro.com** for information on global distributors and representatives or contact **sales@energymicro.com** for additional information.

Americas	Europe, Middle East and Africa	Asia and Pacific
www.energymicro.com/americas	www.energymicro.com/emea	www.energymicro.com/asia

Table of Contents

- 1. Oscillator Theory 2
 - 1.1. What is an oscillator 2
 - 1.2. Basic Principle of Oscillators 2
 - 1.3. Modeling the Crystal 3
- 2. EFM32 Crystal Oscillators 5
 - 2.1. Timeout and Glitch Detection 5
 - 2.2. Oscillator Configuration in energyAware Designer 5
 - 2.3. External Clock and Buffered Sine Input 6
- 3. Crystal Parameters 7
 - 3.1. Quality Factor 7
 - 3.2. Load Capacitance 7
 - 3.3. Equivalent Series Resistance 7
 - 3.4. Frequency Pulling 8
 - 3.5. Drive Level 8
 - 3.6. Minimum Negative Resistance 8
 - 3.7. Frequency Stability 9
 - 3.8. Frequency Tolerance 9
 - 3.9. PCB Layout 9
 - 3.10. Software Configuration 9
- 4. Reducing Power Consumption 10
- 5. Recommended Crystals 11
 - 5.1. Crystal Specifications 12
- 6. Revision History 14
 - 6.1. Revision 1.21 14
 - 6.2. Revision 1.20 14
 - 6.3. Revision 1.10 14
 - 6.4. Revision 1.00 14
- A. Disclaimer and Trademarks 15
 - A.1. Disclaimer 15
 - A.2. Trademark Information 15
- B. Contact Information 16
 - B.1. Energy Micro Corporate Headquarters 16
 - B.2. Global Contacts 16

List of Figures

- 1.1. Feedback Oscillator Loop 2
- 1.2. The Electric Equivalent Circuit of a Crystal 3
- 1.3. Reactance vs. Frequency 4
- 2.1. The Pierce Oscillator in the EFM32 5

List of Tables

5.1. 48MHz Crystals	12
5.2. 32MHz Crystals	12
5.3. 4MHz Crystals	12
5.4. 32768Hz Crystals	12

List of Equations

1.1. Crystal Oscillator Series Resonant Frequency	4
1.2. Crystal Oscillator Anti-Resonant Frequency	4
1.3. Parallel Crystal Oscillator Frequency	4
3.1. Q-Factor	7
3.2. Load Capacitance	7
3.3. Equivalent Series Resistance	7
3.4. Pullability	8
3.5. Drive Level	8
3.6. Negative resistance	8
3.7. Minimum negative resistance	8
4.1. Drive Level/Power Dissipation in Crystal	10

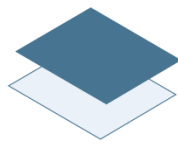

ENERGY[®]
micro

*Energy Micro AS
Sandakerveien 118
P.O. Box 4633 Nydalen
N-0405 Oslo
Norway*

www.energymicro.com